



# S1 Turbo

**NEW! OPTIONAL:**  
Condensing boiler technology  
Retrofittable pellet unit

**A++**

with condensing  
heat exchanger  
and controls

**5 YEAR  
WARRANTY**  
subject to WARRANTY CONDITIONS



# Heating with firewood

For over 50 years, Froling has specialised in using wood as an efficient source of energy. Today the name Froling represents modern biomass heating technology. Froling firewood, wood chip and pellet boilers are successfully in operation all over Europe. All of our products are manufactured in our factories in Austria and Germany, and our extensive service network ensures that we can handle all inquiries quickly.



## The fuel: firewood (up to 56 cm)

Wood is a home-grown and environmentally friendly fuel, that is highly sustainable. It is CO<sub>2</sub> neutral and is not affected by international crises. The production of firewood and pellets ensures stable jobs in the industry. Looking at it from an environmental and economical point of view, wood is the ideal fuel. The quality class is determined by the wood used.



## The new S1 Turbo firewood boiler

Froling's new firewood boiler (15 - 20 kW) combines all the features of a state-of-the-art biomass combustion system. The speed-regulated induced draught fan ensures constant high quality combustion, and the carbonisation gas extraction system prevents flue gas from escaping, even when topping up. The new S1 Turbo stands out for its high efficiency and long refilling intervals, as well as its low emissions and low energy consumption.

The new air duct concept in Froling's S1 Turbo firewood boiler automatically regulates the heating, primary and secondary air with a single actuator. Thanks to the special air ducts for pre-heating, the fuel loading chamber door can be closed very soon after lighting. Heating with firewood can be that convenient!



## Pellet unit can be retrofitted at any time

The S1 Turbo F with pellet flange is the ideal solution for people who are currently only burning firewood. With the S1 Turbo F with pellet flange, the pellet unit can be retrofitted later at any time.

# The latest technology

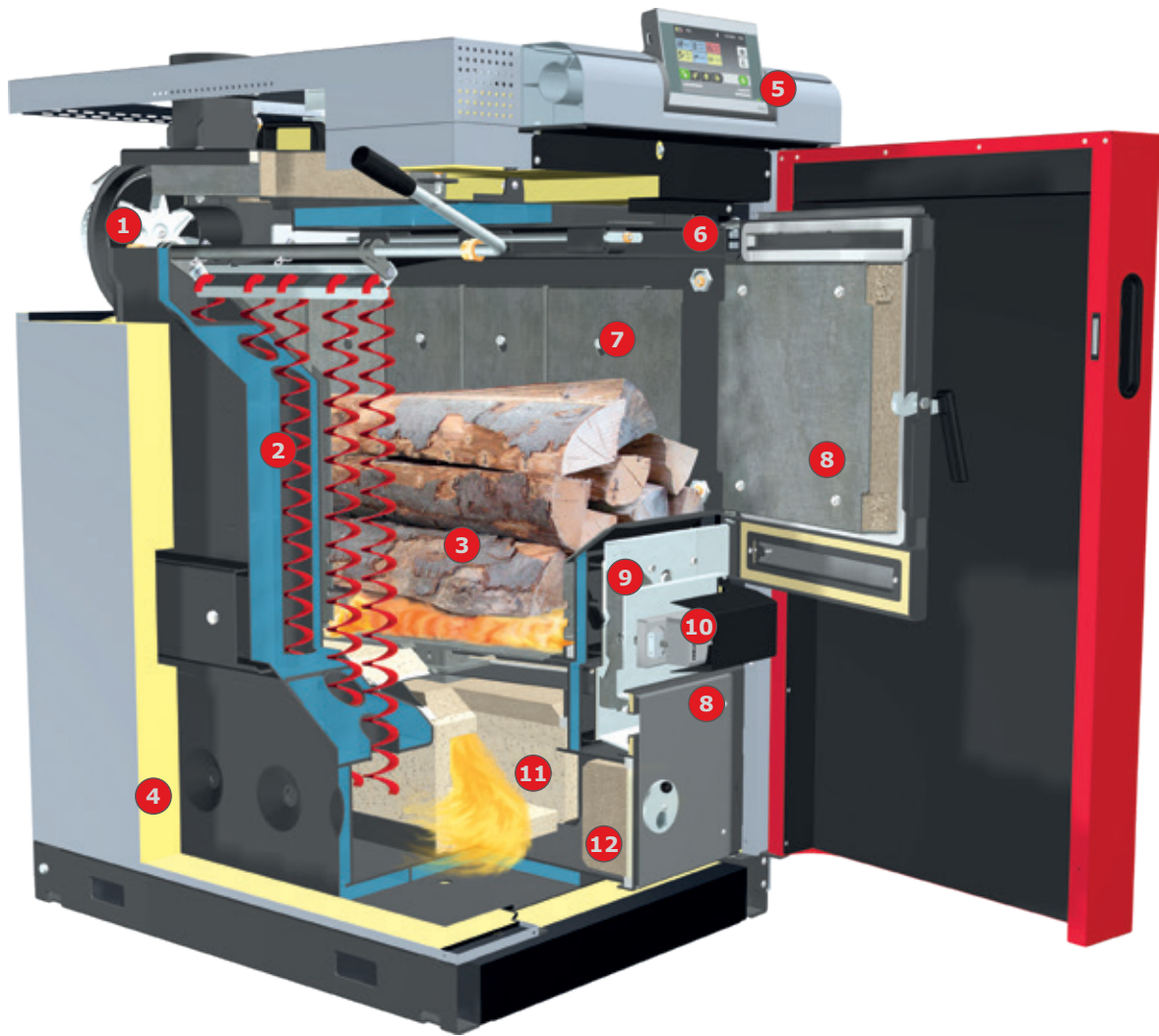

## The firewood boiler with special benefits:

- 1 Speed-regulated, low-noise induced draught fan for maximum ease of use.
- 2 WOS system (Efficiency Optimisation System) as standard, for high efficiency and user-friendly cleaning from outside.
- 3 Large fuel loading chamber for logs up to 56 cm in length guarantees longer periods between refilling.
- 4 Top quality insulation to minimise radiant heat loss.
- 5 Lambdatronic S 3200 control with 7" touch display and innovative bus technology
- 6 Carbonisation gas extraction system prevents smoke escaping during reloading.
- 7 Cladding to protect the inner wall of the boiler and for a longer service life.
- 8 Air-cooled fuel loading chamber and cleaning door to minimise radiant heat loss.
- 9 Special automatic pre-heating with regulated air ducts.
- 10 Servomotor for automatic control of heating, primary and secondary air.
- 11 High-temperature firebrick-lined combustion chamber (easy to replace parts).
- 12 Large cleaning port door for easy ash removal and cleaning from the front.



## State-of-the-art technology and intelligent features



**Feature:** Large fuel loading chamber for logs up to 56 cm in length

- Advantages:
- Easy loading
  - Long combustion time
  - Long reloading intervals

The S1 Turbo can burn firewood up to a length of 56 cm. It is conveniently filled from the front, and the large loading chamber ensures long intervals between reloading. The aprons protect the interior walls of the boiler, guaranteeing a long service life.

# Intelligent features

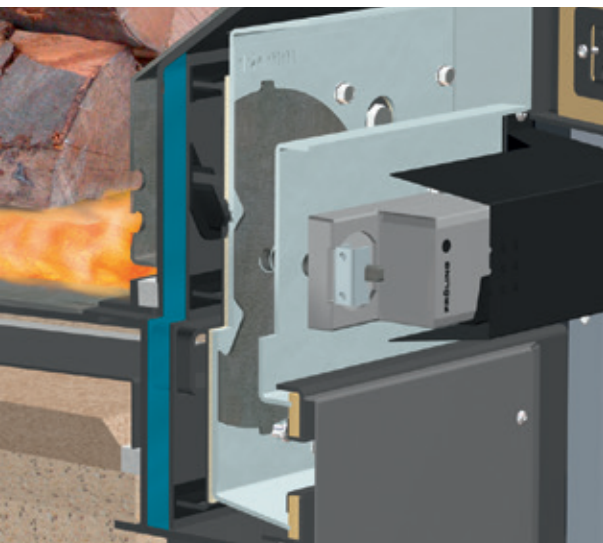

## **Feature: unique air duct system**

- Advantages:
- Regulated supply of air for pre-heating
  - Optimal combustion conditions

A unique design: both the primary and secondary air, as well as the heating air, are automatically regulated in the new S1 Turbo with just one servomotor. This means that in every stage of the heating process - from heating up to burnout - the exact amount of air is supplied, creating the perfect combustion conditions. Furthermore, thanks to the regulated air supply for pre-heating, the door can be closed just a short time after lighting. Heating with firewood can be that easy!

## **Feature: high-temperature firebrick-lined combustion chamber**

- Advantages:
- Low emissions
  - Easy cleaning
  - Long lifespan

The hot combustion zone in the combustion chamber keeps emissions levels low. The new shape of the combustion chamber makes it especially easy to clean. Furthermore, its new construction makes maintaining the combustion chamber a breeze as the firebricks are very easy to replace.

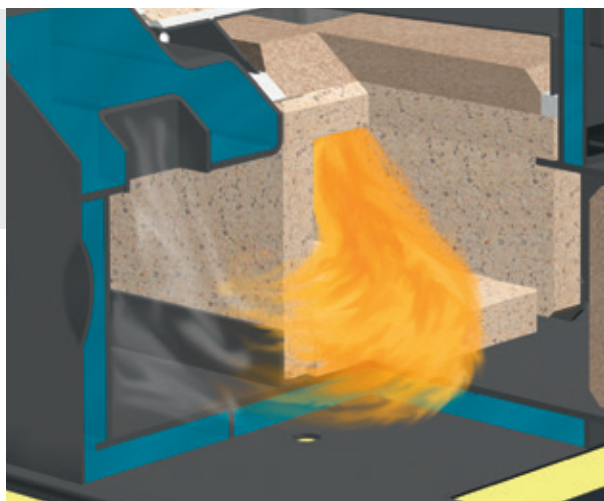

## **Feature: air-cooled fuel loading chamber and cleaning doors**

- Advantages:
- Maximum ease of use
  - Low radiant heat losses
  - High levels of efficiency

Thanks to the new air duct concept, the combustion air is taken in via the fuel loading chamber and combustion chamber doors. This air cooling ensures low temperatures at the boiler's operating elements, thus offering optimum convenience for the user. Furthermore, the low radiant heat losses guarantee excellent efficiency.

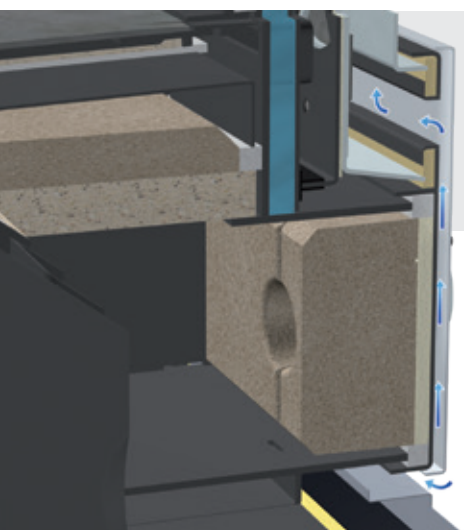

# S1 Turbo

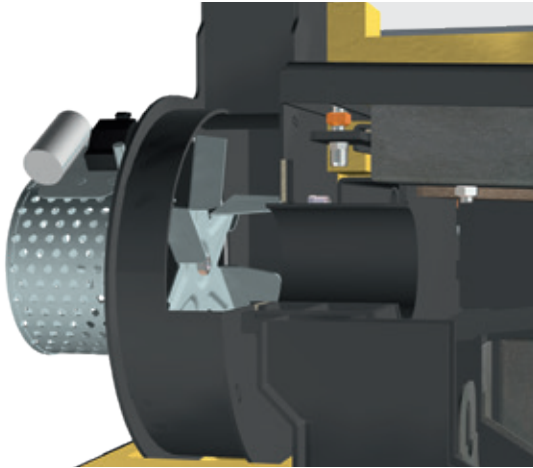

- Feature:** **speed-regulated induced draught fan**
- Advantages:
- Maximum ease of use
  - Smooth boiler start
  - Constant stabilisation during combustion

The speed-controlled induced draught fan is a standard component of the unit, which further enhances the reliability of the S1 Turbo. This means that the boiler can be started easily even if the chimney is cold. The speed regulation device in the induced draught fan stabilises combustion throughout the heating process and adjusts the output according to requirements.

**Feature:** **WOS system as standard**

- Advantages:
- Even more efficient
  - Easy cleaning from outside
  - Fuel economy

We never compromise on convenience. The WOS (Efficiency Optimization System), a standard part of the S1 Turbo, consists of special turbulators which are placed in the heat exchanger pipes. The lever arm mechanism ensures easy cleaning of the heating surfaces from the outside. An additional benefit of this mechanism is that it ensures higher efficiency and fuel savings.

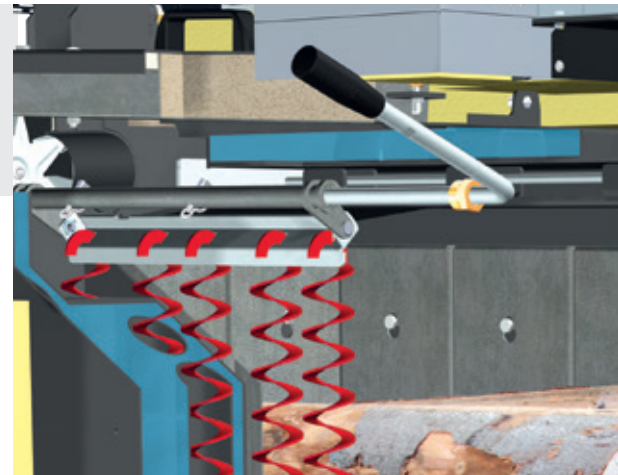

**Feature:** **special carbonisation gas extraction system**

- Advantages:
- Easy pre-heating
  - No flue gas escapes during reloading
  - Boiler room stays clean

The integrated carbonisation gas duct flap makes pre-heating even easier. The flap is closed manually before lighting to provide a better draught during the pre-heating process. The carbonisation gas duct flap opens automatically when the fuel loading chamber door is closed. This then reactivates the carbonisation gas extraction system, thus preventing smoke and gas from escaping when reloading.

**Feature:** **Pellet flange for the S1 Turbo F (optional)**

- Advantages:
- Pellet unit can be retrofitted at any time
  - Two systems perfectly combined

The S1 Turbo F with pellet flange is the ideal solution for people who are currently only burning firewood. With the S1 Turbo F with pellet flange, the pellet unit can be retrofitted at any time.

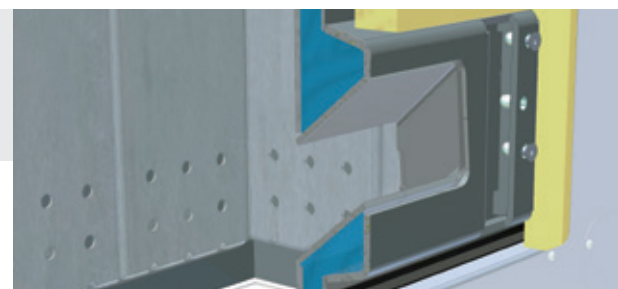

Efficiencies  
up to 102.8%

# Innovative: Condensing boiler technology for firewood boilers



The Froling firewood boilers are the only ones in the world, which are also available with **innovative condensing boiler technology** (optional). The flue gas contains energy, which escapes unused up the chimney with conventional solutions, but an additional heat exchanger positioned on the back of the boiler makes use of it for the heating system. This increases the **boiler efficiency to over 102,8 percent (Hu)**, an unprecedented level for firewood boilers. Froling won the innovation prize at the ExpoEnergy trade fair in Wels for condensing boiler technology in the biomass sector as early as 1996, making it a pioneer in the field. The heat exchanger is made of high-quality stainless steel. It is cleaned using a water flushing system. The module can also be retrofitted.



## Advantages

- Lower fuel costs
- Filtration of the flue gas
- Reduced emissions
- Automatic cleaning
- The condensing module can also be retrofitted at any time



## Overview of condensing heat exchanger:

- 1 Heat exchanger made of stainless steel
- 2 Automatic rinsing device
- 3 Drain with siphon for condensate drainage

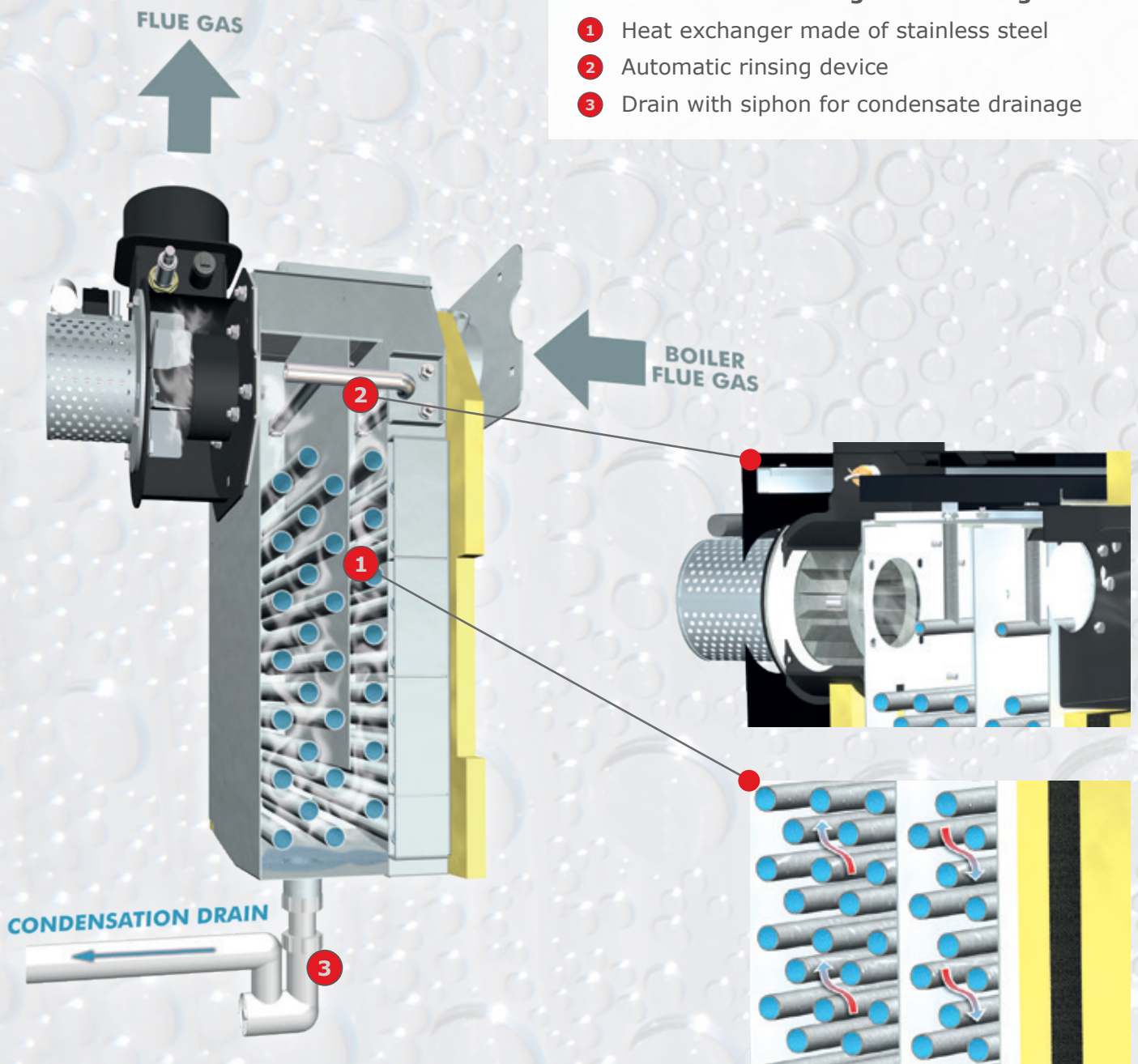

## Requirements for optimal use of condensing technology:

- The return temperature should be as low as possible (e.g. floor or wall heating)
- Moisture-resistant and soot-fire-resistant exhaust system (W3G approval)
- Duct connection for condensate drainage and drainage of the rinse water

# System convenience

## Lambdatronic S 3200 control

With the new Lambdatronic S 3200 boiler controller, Froling is taking a step into the future. The control unit is optimised to suit any requirement. An individually adjustable viewing angle ensures that all operating statuses are clearly displayed. Exact combustion control thanks to lambda control **with broadband probe** as standard. The menu structure is ideally organised to ensure easy operation. All essential functions can be selected by simply pressing a button.



### Lambdatronic S 3200 control

Advantages:

- Exact combustion control with broadband probe lambda control
- Large, clear control unit

### NEW! 7" Touch-Display

Advantages:

- Individual installation of your own heating system
- Even more comfortable operation of the boiler thanks to a larger touch screen

## NEW! SIMPLIFICATION OF BOILER SOFTWARE

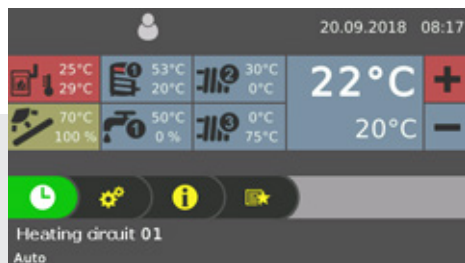

Fig. 1 General overview of heating circuit

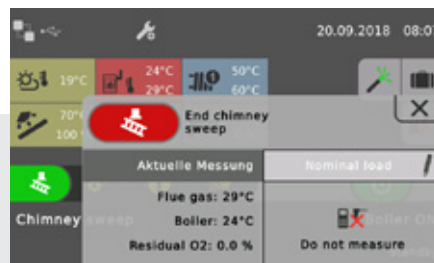

Fig. 2 View of the chimney sweeper function

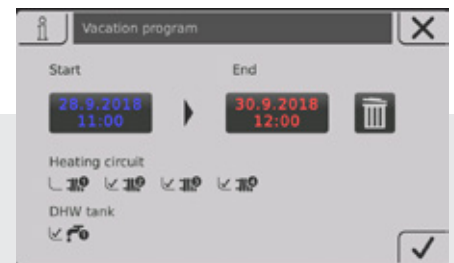

Fig. 3 Overview of the new holiday mode

### Firewood reload calculation

Too much firewood can result in fuel that is not completely burnt despite the storage tank being loaded. The integrated reload calculation can be used through simple parameterization of the storage tank type and the storage tank volume. Taking into account the current storage tank charge, the boiler control calculates the missing energy. When the boiler door is opened, the required amount of fuel for loading the storage tank is displayed in kilograms.



**NEW:**

## EVERYTHING AT A GLANCE WITH THE NEW FROLING APP

- ✓ Simple and intuitive operation of the boiler
- ✓ Status information can be called up and changed within seconds
- ✓ Individual naming of the heating circuits
- ✓ Status changes are transmitted directly to the user (e.g. via e-mail or push notifications)
- ✓ No additional hardware required (e.g. Internet gateway)



With the new Froling App, you can check and control your Froling boiler online from anywhere at any time. You can read and modify the main status information and settings easily and conveniently online. You can also specify which status messages you want to be informed about via SMS or e-mail (e.g. when the ash box is to be emptied or in the event of a fault message).

With optimized tablet view!

Froling boiler (software core module from version V50.04 B05.16) with boiler touch display (from version V60.01 B01.34), a (broadband) internet connection and a tablet/smartphone with IOS or Android operating system. Once the boiler has been connected to the internet and activated, the system can be accessed 24/7 from anywhere using a web-enabled device (mobile, tablet, PC, etc.). The app is available in the Android Play Store and IOS App Store.



**SMART  
HOME**

## FLEXIBLE SOLUTION



Enjoy smart, convenient and piece-of-mind living with the Smart Home connection options from Froling.

**Loxone:** Combine your Froling heating system with the Loxone Miniserver and the new Froling Extension and implement individual boiler control on the basis of the single room control of the Loxone Smart Home.

**Advantages:** Easy operation and viewing of the heating circuit via the Loxone Miniserver, immediate notification of status changes and individual operating modes for each situation (presence, holiday, economy mode, etc.)



**Mod bus:** Via the Froling mod bus interface, the system can be integrated into a building management system.

# System convenience



## FRA room temperature sensor

By using the just 8x8 cm FRA room temperature sensor, the main modes of the corresponding heating circuit can be easily selected and adjusted. The FRA can be connected both with and without affecting the store. The adjusting wheel allows you to change the room temperature by up to  $\pm 3^{\circ}\text{C}$ .

## RBG 3200 Touch room console

The RBG 3200 Touch has an impressive touchpad interface. The menu structure means it is intuitive and easy to use. The 17x10 cm console with colour screen shows the most important functions at a glance and automatically adjusts the background lighting to the conditions. The room consoles are connected to the boiler controller using a bus cable.



## Froling visualisation software 3200

- Advantages:
- Monitor and operate from your PC
  - Record boiler data
  - Remote control via modem

The optional boiler visualisation software enables easy boiler control from a computer. All operating values and customer parameters can be displayed and modified. The familiar Windows interface and clear menu structure make it easy to use. It is possible to connect to the visualisation software using a telephone network modem. This means that the heating system can be monitored from any location. It is also possible to connect to an existing LAN using an optional adapter.

## Froling SMS-Box

- Advantages:
- Text message alerts
  - Active heating system control

The Froling SMS box allows you to monitor the boiler and actively control the heating system by text message. It can be programmed directly from a mobile phone and has two error message inputs and two remote switch outputs. The alarm and message texts can be configured as required. This includes switching, e.g. from setback mode to party mode (only in conjunction with room temperature sensor). An automatic response confirms the execution of the command that was sent.



**Feature:** systems engineering for optimum energy consumption

- Advantages:
- Complete solutions for all requirements
  - Components work perfectly together
  - Integrated solar power

The perfect combination – Please also see our “Tank systems” brochure

Froiling systems engineering offers efficient energy management. Up to 4 storage tanks, 8 hot water tanks and 18 heating circuits can help manage the heating. You can also benefit from the ability to integrate other means of energy production such as solar panel systems.

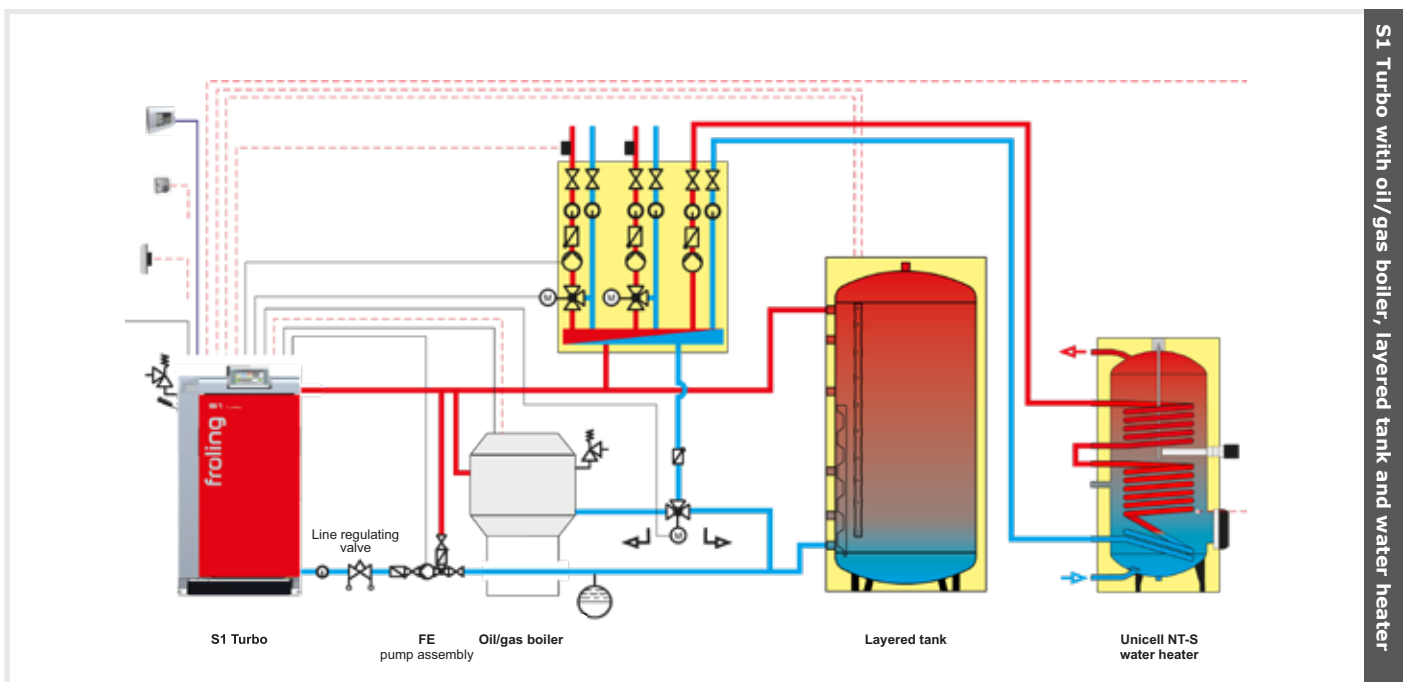
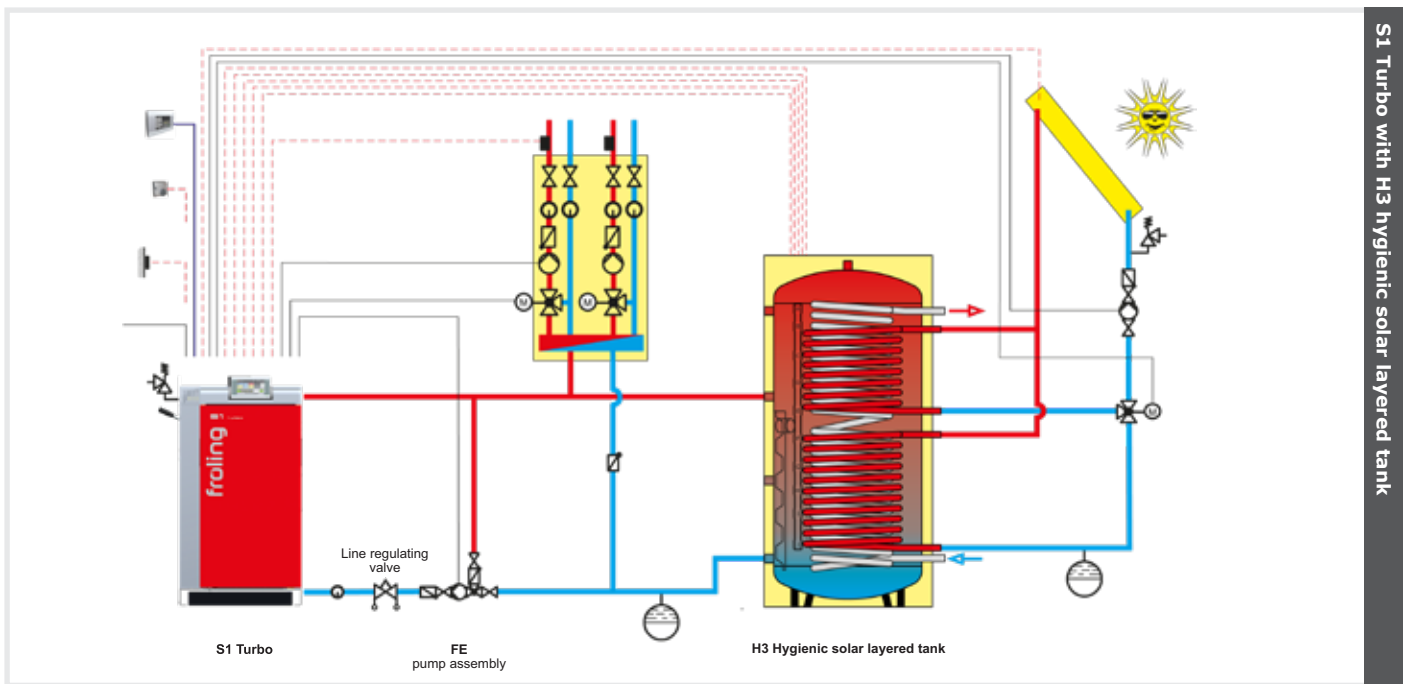

# Recommended clearances

S1 Turbo

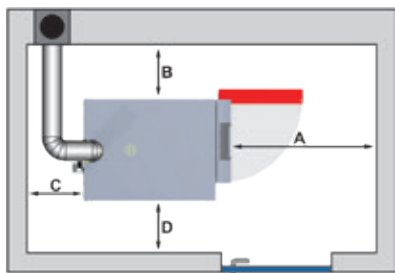

S1 Turbo F / SP Dual compact

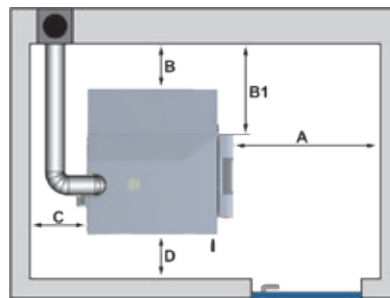

Minimum distances - S1 Turbo	[mm]	15	20
A Distance between front of boiler and wall		800	800
B Distance between side of boiler and wall		500	500
C Distance between rear of boiler and wall		400	400
D Distance between side of boiler with WOS lever and wall		500 (200 <sup>1</sup> )	500 (200 <sup>1</sup> )
Minimum room height		2000	

Minimum distances - S1 Turbo F (SP Dual Compact)	[mm]	15	20
A Distance between front of boiler and wall		800	800
B Distance between side of boiler with heat exchanger lever and pellet unit and wall		500	500
B1 Distance between side of boiler without pellet unit and wall		815	815
C Distance between rear of boiler and wall		400	400
D Distance between side of boiler with WOS lever and wall		500 (200 <sup>1</sup> )	500 (200 <sup>1</sup> )
Minimum room height		2000	

<sup>1</sup> Maintenance on the boiler heat exchanger is only possible from the front

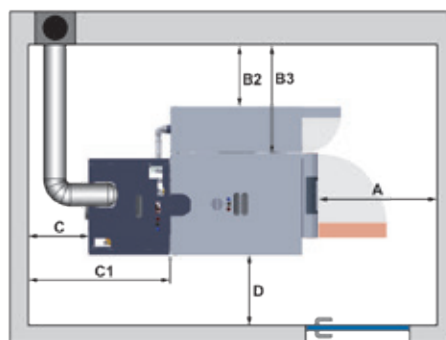
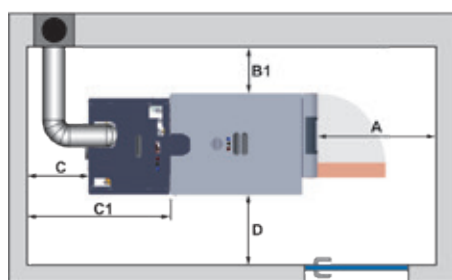

Mindestabstände - S1 Turbo / S1 Turbo F (SP Dual compact) with condensing boiler technology	[mm]	15-20
A Distance - front of boiler to wall		800
B1 Distance - boiler side to wall - S1 Turbo		200
B2 Distance - boiler side to wall - SP Dual compact		500
B3 Distance - boiler side to wall - S1 Turbo, if pellet unit is retrofitted		815
C Space required incl. maintenance area for induced draught fan with calorific value heat exchanger		250
C1 Space required to retrofit a calorific value heat exchanger		800
D Distance - boiler side to wall		500 (200*)

\* Maintenance work to boiler's heat exchanger only possible from front

# S1 Turbo

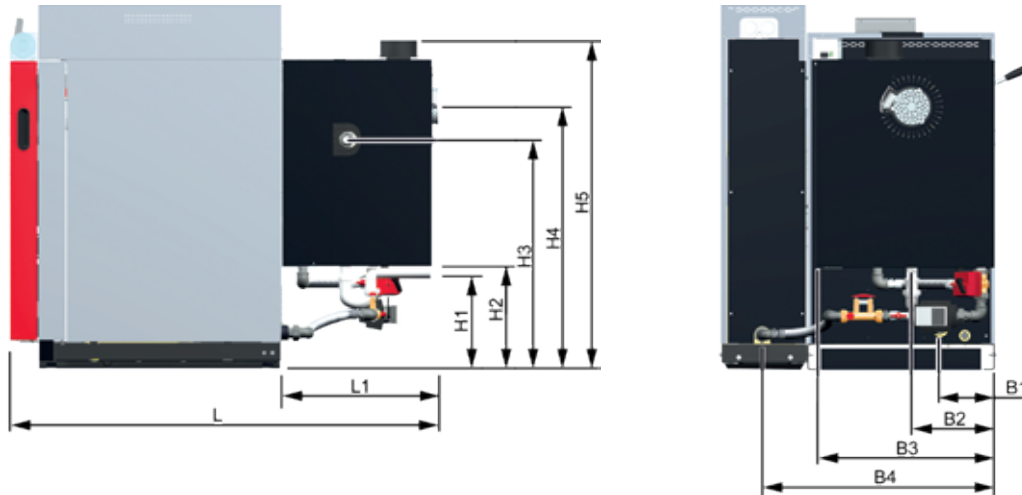

Dimensions - S1 Turbo F / SP Dual compact with condensing boiler technology	[mm]	15-20
L Length of boiler + condensing boiler heat exchanger		1575
L1 Length of condensing boiler heat exchanger		575
B1 Distance from boiler return to boiler side for S1 Turbo		200
B2 Distance from condensate drain to boiler side		305
B3 Width of condensing heat exchanger		650
B4 Distance from boiler return to boiler side for SP Dual compact		850
H1 Height of condensate drain connection		245 - 350
H2 Height - lower edge of the condensing boiler heat exchanger		370
H3 Height of return connection		840
H4 Height of draft fan connection		965
H5 Height of exhaust pipe connection		1205
Flue pipe diameter		132

Technical specifications - S1 Turbo F / SP Dual compact with condensing boiler technology		15	20
Nominal heat output - Log wood operation / pellet operation	[kW]	16,5 kW / 4,8 - 16,5 kW	21,4 kW / 4,8 - 21,4 kW
Boiler efficiency	[%]	101,9	102,8
Energy label*			
Electrical power	[W]	58	55
Hopper capacity	[l]	80	
Filling door (width/height)	[mm]	350 / 360	
Water content - log boiler / pellet unit	[l]	90 / 15	
Weight of the condensing heat exchanger	[kg]	90	
Capacity of the pellet container (automatic charging)	[kg]	40	

\* Configuration label (boiler + control + calorific value)

# Technical data

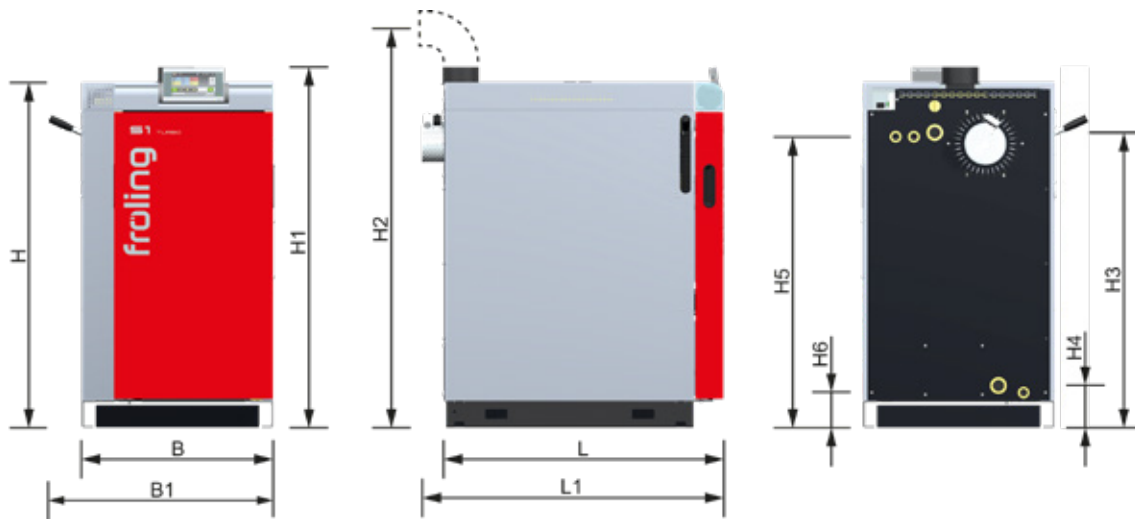

Dimensions - S1 Turbo		15	20
L	Length of boiler [mm]	1000	1000
L1	Total length including induced draught fan [mm]	1080	1080
B	Width of boiler [mm]	685	685
B1	Width of boiler incl. WOS lever [mm]	790	790
H	Height of boiler [mm]	1235	1235
H1	Total height incl. flue gas nozzle [mm]	1300	1300
H2	Height, flue gas pipe connection [mm]	1395	1395
H3	Height, flow connection [mm]	1055	1055
H4	Height, return connection [mm]	150	150
H5	Height, safety battery connection [mm]	1040	1040
H6	Height, drain [mm]	125	125
	Flue pipe diameter [mm]	129	129

Technical specifications - S1 Turbo		15	20
Nominal output	[kW]	15	20
Energy (ErP) label*		A*	A*
Power connection	[V/Hz/A]	230V / 50Hz / fused C16A	
Power consumption	[W]	37	42
Weight of boiler incl. insulation and control	[kg]	455	465
Dimensions of fuel loading door (width/height)	[mm]	350 / 360	350 / 360
Fuel loading chamber capacity	[l]	80	80

\* Composite label (boiler + controls)

Your Froling partner:



**Heizkessel- und Behälterbau GesmbH  
A-4710 Grieskirchen, Industriestr. 12**

AT: Tel +43 (0) 7248 606 • Fax +43 (0) 7248 606-600  
DE: Tel +49 (0) 89 927 926-0 • Fax +49 (0) 89 927 926-219  
E-mail: info@froeling.com • Internet: www.froeling.com